

HELISTAR

EUTS-□□

通軸式電磁離合器. 制動器組合

Tandem shaft type clutch & brake unit

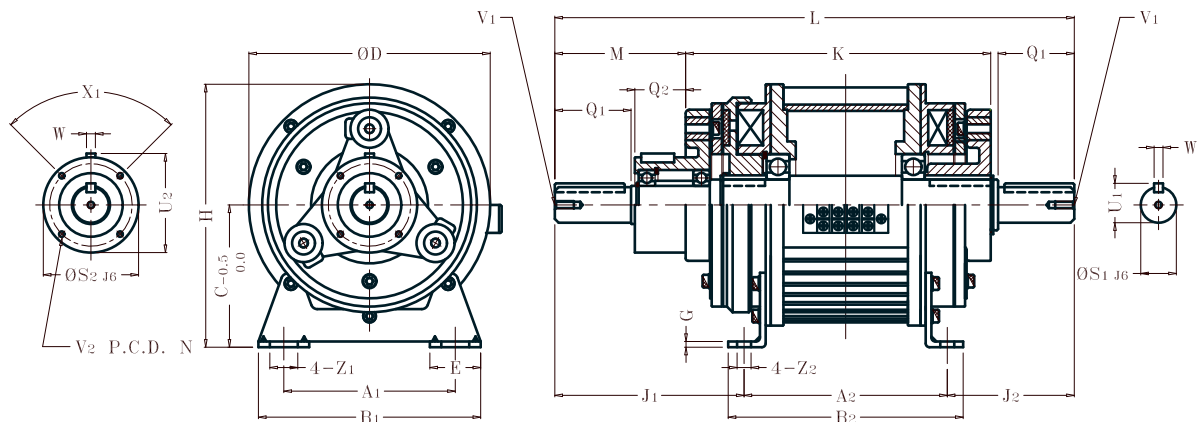

型號 Model	0.6	1.5	2.5	5	10	20	40	
本體 (Body)	A1	52.5	65	80	105	135	155	195
	A2	75	90	110	135	160	200	240
	B1	80	90	110	140	175	200	240
	B2	90	105	130	160	185	230	270
	C	55	65	80	90	112	132	160
	D	80	100	125	150	190	230	290
	E	27.5	27.5	27.5	35	43	45	47.5
	F	53	61	72	81	97	109	129
	G	2.6	2.6	3.2	3.2	4.5	6	20
	H	95	115	142.5	165	207	247	305
	J1	65.5	78.5	98	121.5	149	187	238
	J2	40.5	48.5	62	73.5	90	117	154
	K	105.5	126.5	154	184	221	276	334
	L	181	217	270	330	399	504	632
	M	47	57	72	92	113	142	183
	N	33	37	47	52	62	74.5	101.5
	V1	M4*0.7深8	M4*0.7深8	M6*1深11	M6*1深11	M6*1深11	M10*1.5深17	M10*1.5深17
	V2	3-M4*0.7深4	3-M4*0.7深6	4-M4*0.7深8	4-M4*0.7深8	6-M5*0.8深8	4-M6*1深12	8-M6*1深12
	X1	3-120°	3-120°	4-90°	4-90°	6-60°	4-90°	8-45°
	Z1	13.5	13.5	15.5	20	24.5	28	28
Z2	6.5	6.5	9	11.5	11.5	14	14	
軸部 (Shaft)	Q1	25	30	40	50	60	80	110
	Q2	20	25	30	40	50	60	70
	S1	11	14	19	24	28	38	42
	S2	38	45	55	64	75	90	115
	U1	12.5	16	21	27	31	41.5	45.5
	U2	39.5	47	57	67	78	93.5	118.5
	W	4	5	5	7	7	10	12